

SONY[®]

COLOR VIDEO MONITOR

PVM-1380

OPERATING INSTRUCTIONS Page 2

Before operating the unit, please read this manual thoroughly, and retain it for future reference.

MODE D'EMPLOI Page 9

Avant de faire fonctionner cet appareil, prière de lire attentivement ce mode d'emploi et de le conserver à titre de référence ultérieure.

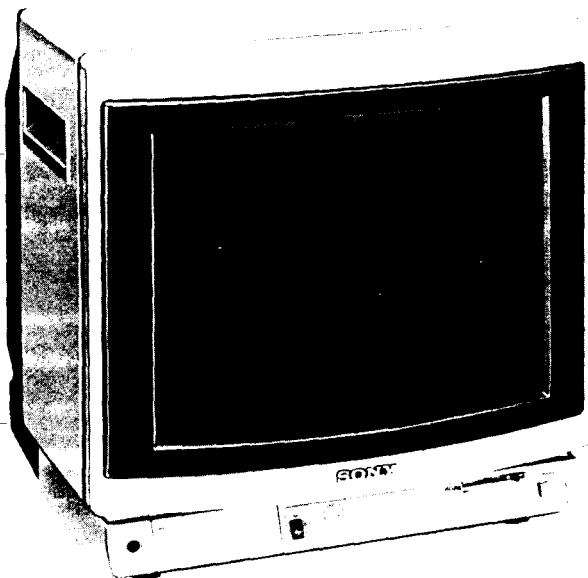

The PVM-1380 color video monitor employs **New black-tinted Trinitron** picture tube which absorbs most ambient light and improves picture contrast remarkably. It also employs **New PanFocus™ Gun** which creates clear, sharp pictures on every portion of the display.

OWNER'S RECORD

The model and serial numbers are located on the rear of the unit. Record the serial number in the space provided below. Refer to these numbers whenever you call upon your authorized Sony dealer regarding this product.

Model No. PVM-1380 Serial No. _____

WARNING

To prevent fire or shock hazard, do not expose the unit to rain or moisture.

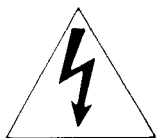
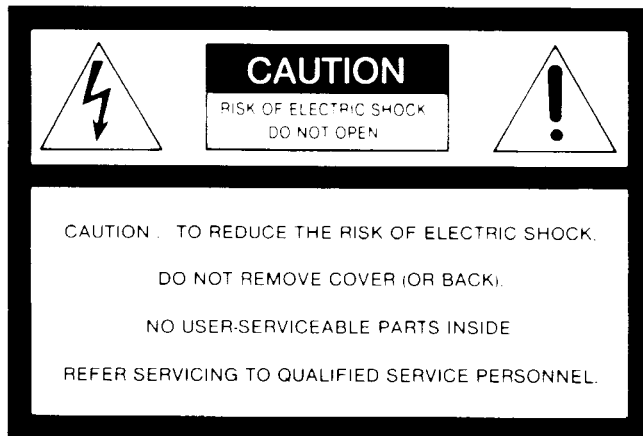

This symbol is intended to alert the user to the presence of uninsulated "dangerous voltage" within the product's enclosure that may be of sufficient magnitude to constitute a risk of electric shock to persons.



This symbol is intended to alert the user to the presence of important operating and maintenance (servicing) instructions in the literature accompanying the appliance.

TABLE OF CONTENTS

Precautions	2
Location and function of controls	
Front panel	3
Rear panel.....	4
System connections	
Connecting a VTR.....	5
Connecting a camera and a microphone.....	6
Connecting several monitors	7
Specifications	8

PRECAUTIONS

Safety

- Operate this unit only on 120 V ac.
- Unplug the unit should any liquid or solid object fall into the cabinet. Have it checked by qualified personnel before operating it any further.
- Unplug the unit from the wall outlet, if it is not to be used for several days.
- Disconnect the ac power cord, by pulling it out by the plug. Never pull the cord itself.

Installation

- Provide adequate air circulation in order to prevent internal heat build-up.
Do not place the unit on rugs or blankets, or near curtains or draperies, which can block the ventilation holes.
- Do not install the unit near heat sources such as radiators or air ducts, nor subject it to direct sunlight, excessive dust, mechanical vibration or shock.

Cleaning

To keep the unit looking brand-new, clean it periodically with a soft cloth. Stubborn stains may be removed using a cloth lightly dampened with a mild detergent solution. Never use strong solvents such as thinner or benzine, or abrasive cleansers, since these will damage the cabinet. Unplug the unit before cleaning it.

Repacking

Retain the carton and packing materials. To ship the unit, repack it as illustrated on the carton.

If you have any questions about this unit, contact your authorized Sony dealer.

LOCATION AND FUNCTION OF CONTROLS

FRONT PANEL

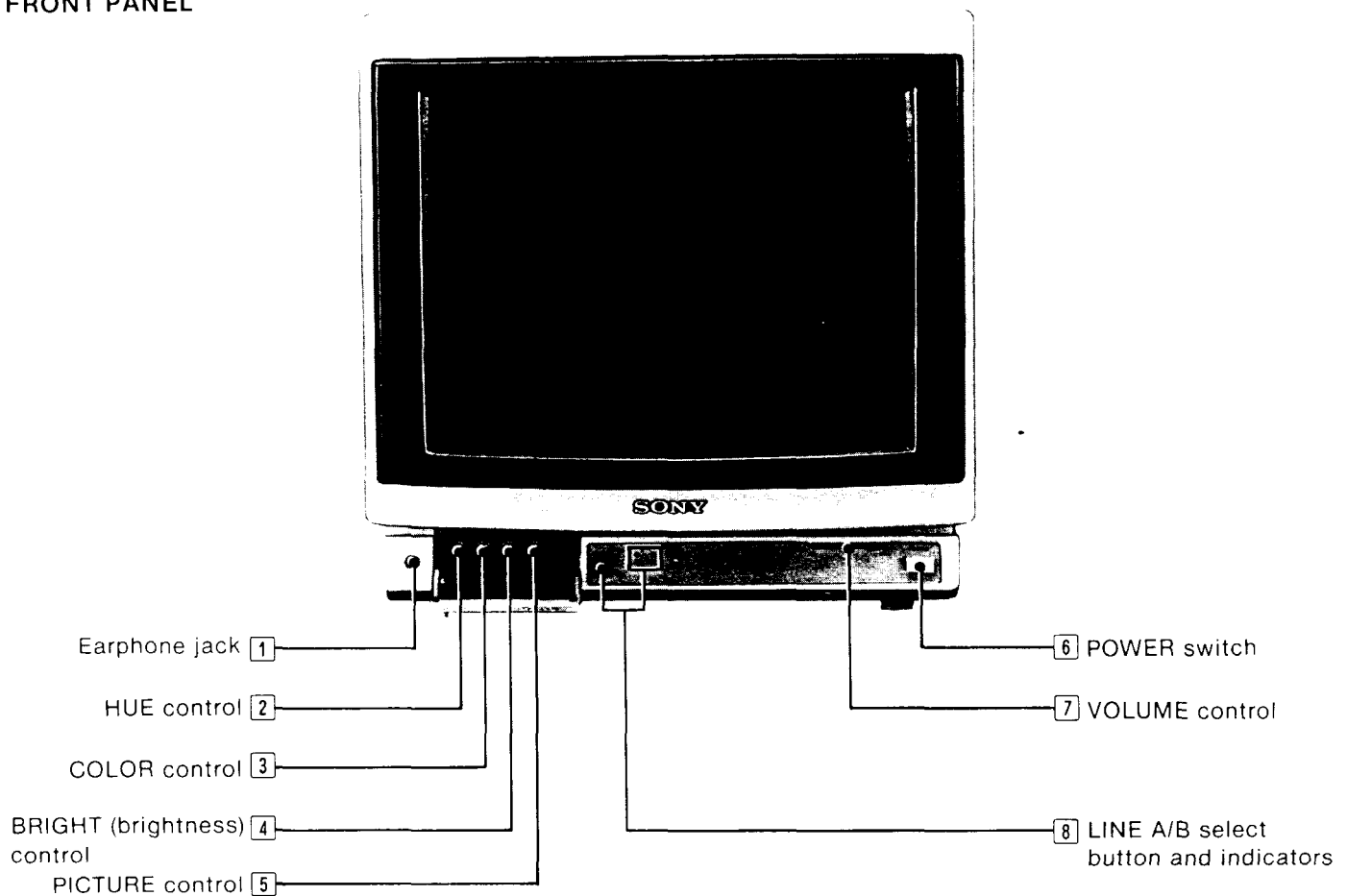

1  **Earphone jack**

Connect an earphone for private listening.

2 **HUE control**

Use to obtain natural skin tones. Clockwise rotation renders greenish skin tones; counterclockwise rotation renders purplish skin tones.

3 **COLOR control**

Adjusts the picture's color intensity. Clockwise rotation makes the picture more vivid.

4 **BRIGHT (brightness) control**

Adjusts the picture's brightness. Clockwise rotation makes the picture brighter.
Normally set this control at the center detent position.

5 **PICTURE control**

Adjusts the picture's contrast, color intensity and brightness simultaneously at the proper ratio.
Normally set this control at the center detent position.

6 **POWER switch**

Press this switch to turn on the monitor. Either of the LINE A/B indicator lights. To turn off the monitor, press the switch again.

7 **VOLUME control**

Slide this control to the right or left to obtain the desired volume; sliding to the right makes the sound louder.

8 **LINE A/B select button and indicators**

Selects the program to be monitored. When this button is not pressed, the LINE A is selected. To select the LINE B, press this button. The indicator lights to show which program has been selected.

LINE A: To monitor the signals fed to the LINE A connectors.

LINE B: To monitor the signals fed to the LINE B connectors or the VTR connector.

REAR PANEL

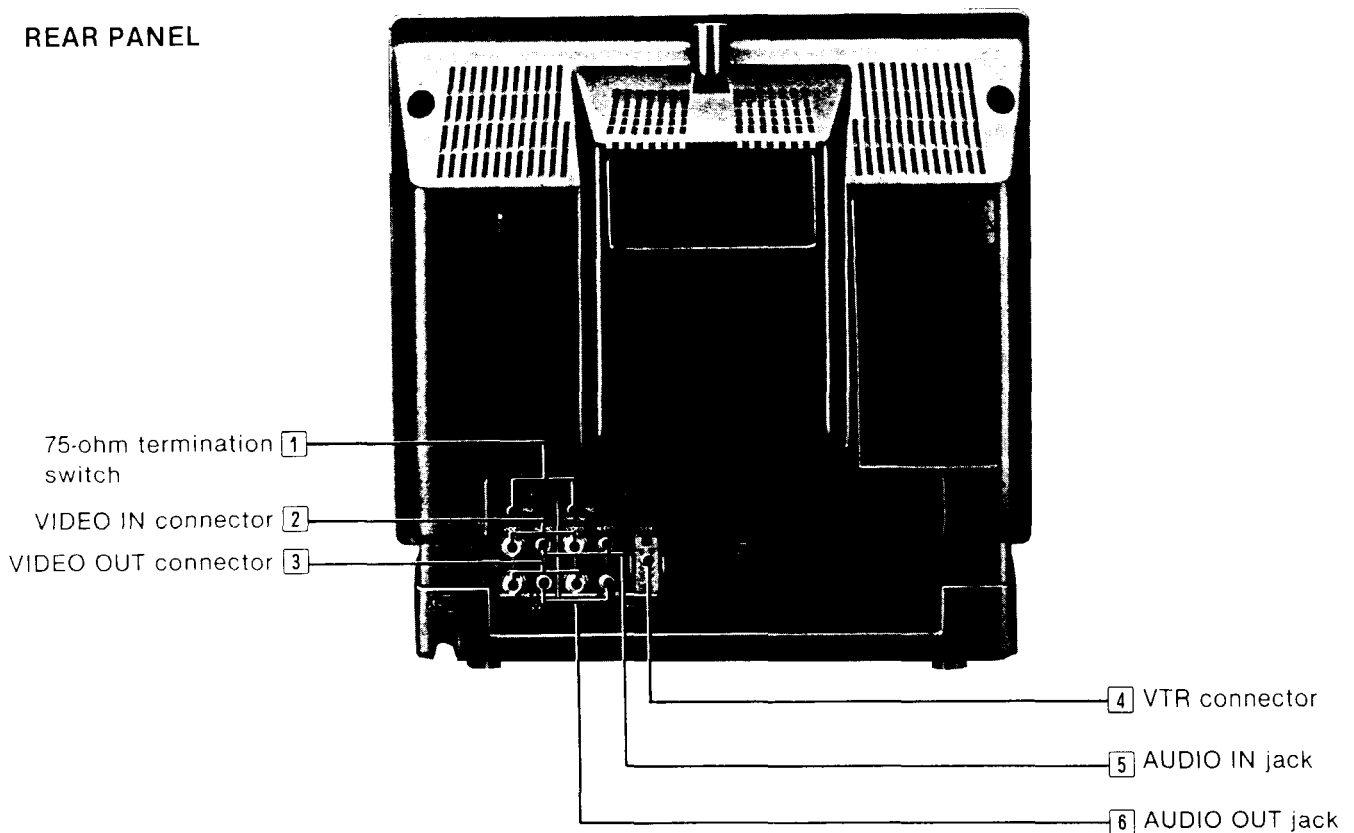

Note on LINE A and B connectors

These are two groups of input and output connectors. Composite video and audio signals fed to the LINE A and B's input connectors are supplied from each output connector (loop-through connection). To select the input signals to LINE A or B, press the LINE A/B select button on the front panel.

1 75-ohm termination switch

Select the position as follows.

- ON:** When the VIDEO OUT connector is not used.
- OFF:** When both the VIDEO IN and VIDEO OUT connectors are used together for loop-through connection.

2 VIDEO IN connector (BNC type)

Receives video signal. Connect to the video output connector of a VTR, color video camera or another monitor.

3 VIDEO OUT connector (BNC type)

Loop-through output of the VIDEO IN connector. Connect to the video input connector of a VTR or another monitor.

4 VTR connector (8-pin)

Receives video and audio playback signals through only one cable.
Connect to the 8-pin TV connector of a VTR with an 8-pin video cable.
To monitor this connector's input signal, select the LINE B by LINE A/B select button on the front panel.

NOTE

- The VTR connector is parallel to the LINE B connectors. Do not use the VTR connector and the LINE B connectors at the same time.
- Be sure that the 75-ohm termination switch of the LINE B is set to ON when the VTR connector is used.
- For connection, use an optional video cable VMC-3P (3 m; 9 feet), -5P (5 m; 15 feet) or -10P (10 m; 33 feet).

5 AUDIO IN jack (PHONO type)

Receives audio signal. Connect to the audio output connector of a VTR, another monitor or a microphone via an amplifier.

6 AUDIO OUT jack (PHONO type)

Loop-through output of the AUDIO IN jack. Connect to the audio input connector of a VTR or another monitor.

SYSTEM CONNECTIONS

CONNECTING A VTR

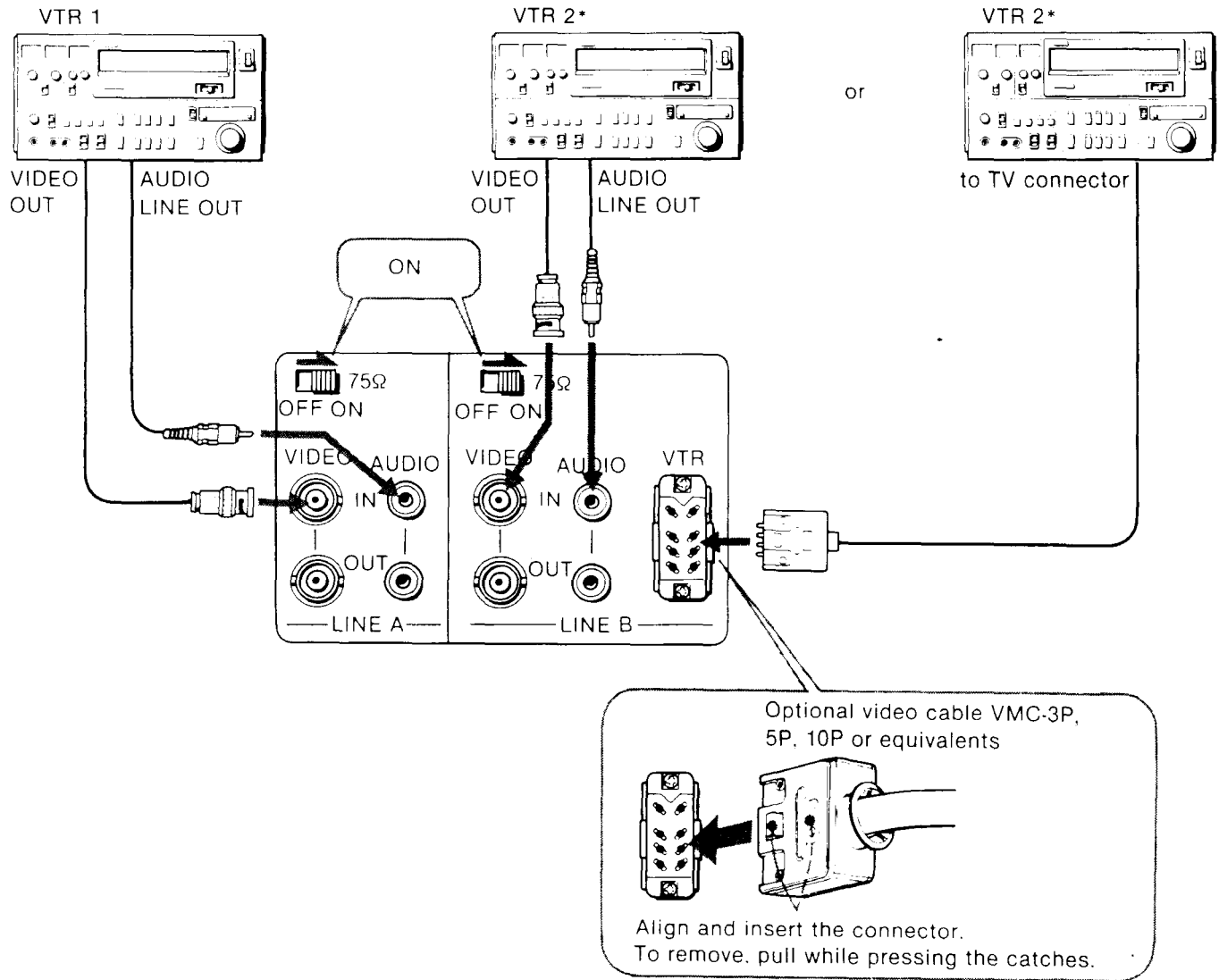

* Do not use the VTR connector and the LINE B connectors at the same time.

CONNECTING A CAMERA AND A MICROPHONE

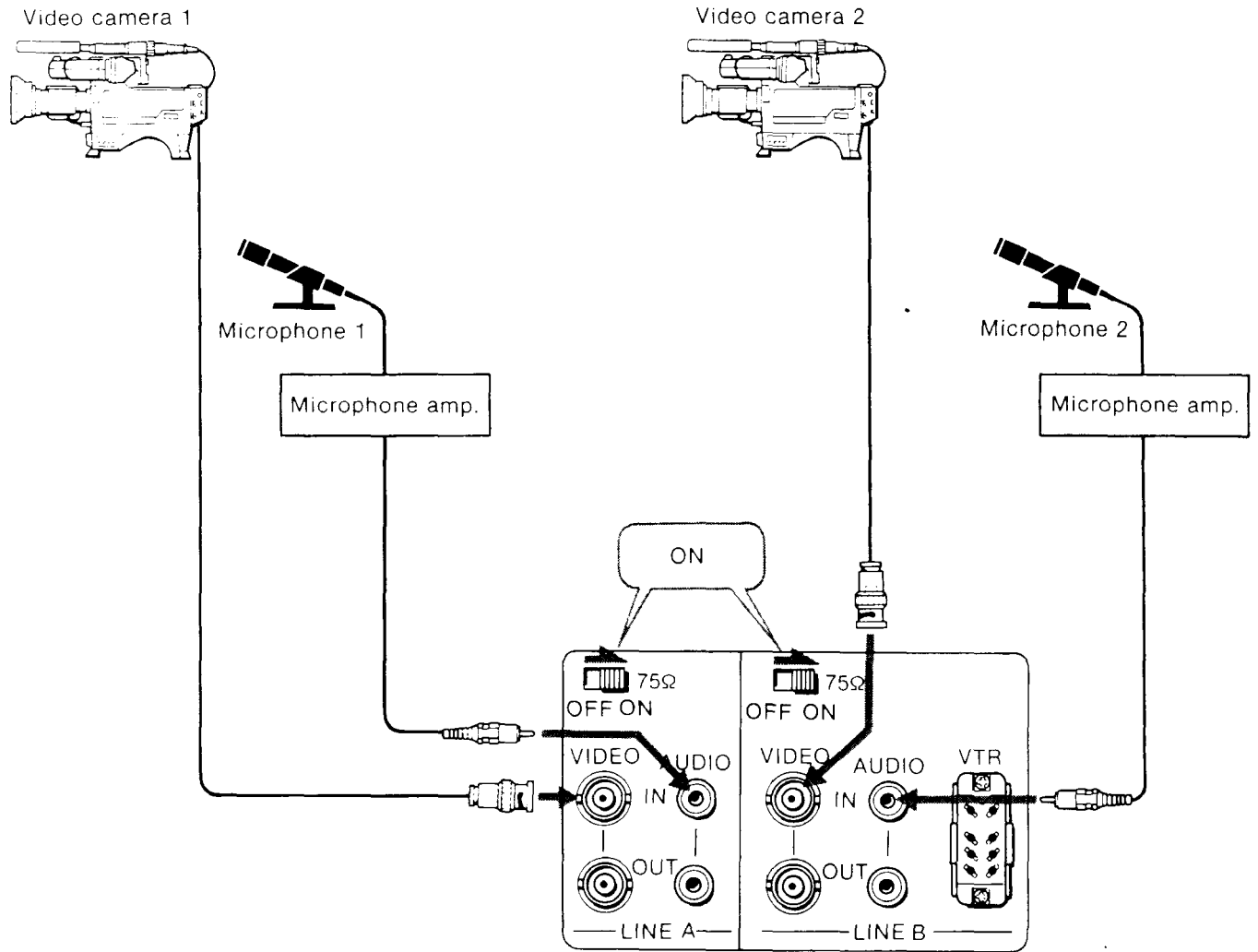

CONNECTING SEVERAL MONITORS

To monitor the same signal on other monitors at the same time, connect the video/audio output connectors to the other monitors' input connectors. (loop-through connection).

Up to 10 monitors can be connected.

Set the 75-ohm termination switch of the last monitor connected to ON, and those of the other monitors to OFF.

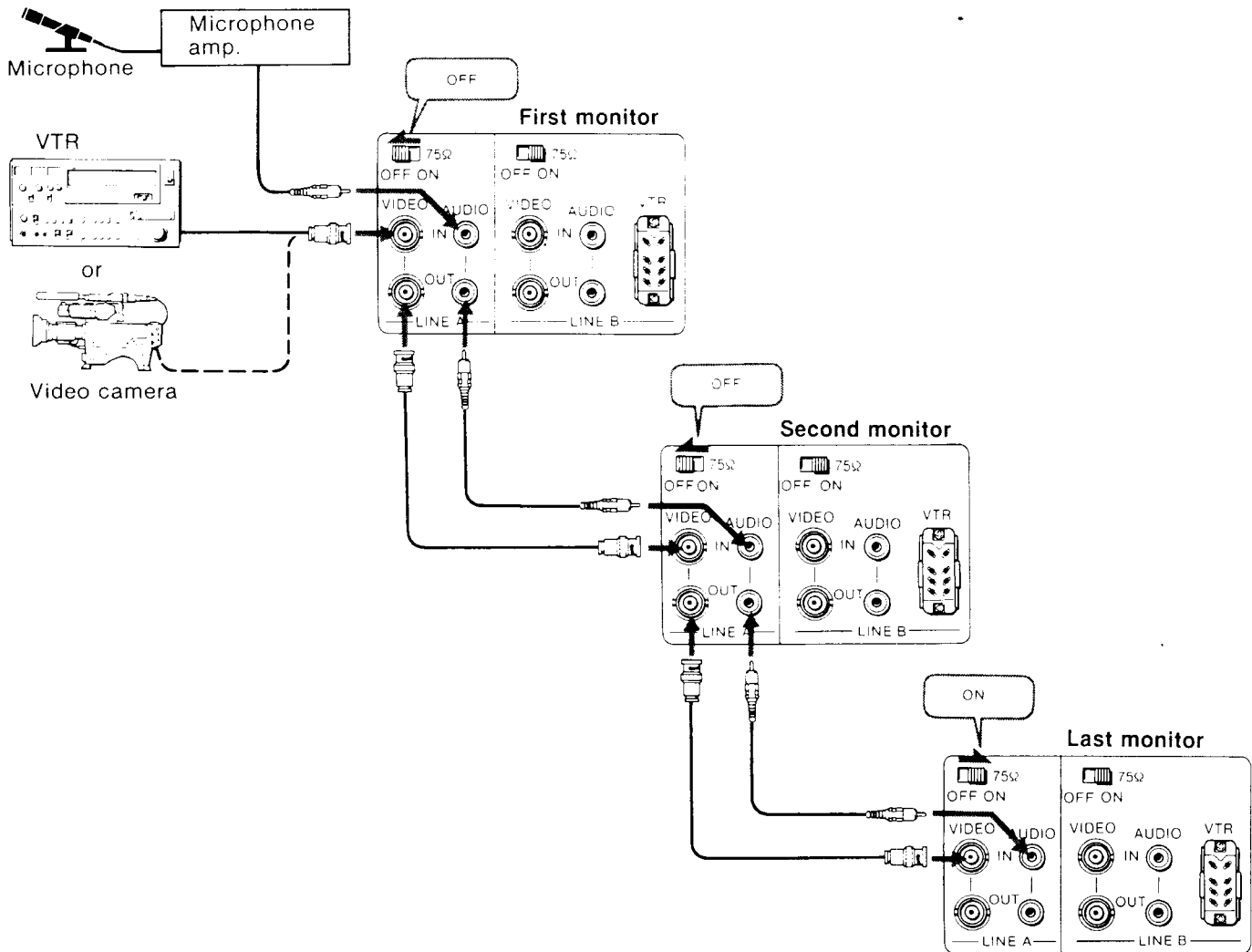

SPECIFICATIONS

Color system	NTSC
Picture tube	Trinitron tube 13-inch picture measured diagonally 90-degree deflection AG Pitch 0.6 mm Black face
Resolution	250 TV lines
Color temperature	9,300°K
Horizontal linearity	± 8%
Vertical linearity	± 10%
Line pull range	Horizontal ± 500 Hz Vertical - 8 Hz
Input return loss	More than 35dB at 4 MHz
Zooming	Less than 5%
Adjustable items	HUE/COLOR/BRIGHT/PICTURE/VOLUME/LINE A/B select button/ POWER ON-OFF
Inputs	VIDEO IN: LINE A and B. BNC connectors, composite 1V p-p $\pm \frac{1}{6}$ dB, sync negative, 75 ohms and high impedance swichable, unbalanced AUDIO IN: LINE A and B, PHONO connector, - 5dBs* high impedance VTR: 8-pin connector, parallel to LINE B * 0dBs = 0.775V
Outputs	VIDEO OUT: BNC connector AUDIO OUT: PHONO connector Output level 1 W
Power requirements	120 V AC, 50/60 Hz
Power consumption	86 W max.
Dimensions	Approx. 365.5 x 366 x 408.5 mm (w/h/d) (14 $\frac{1}{8}$ x 14 $\frac{1}{2}$ x 16 $\frac{1}{8}$ inches)
Weight	11.5 kg (25 lb 57 oz)
Operating temperature	0°C to 40°C (32°F to 104°F)

Design and specifications subject to change without notice.